

Paramount

Model#: FPT1848

Item#: FP-399-ULC-PC23A-E

OUTDOOR FIREPIT

INSTRUCTION MANUAL



WARNING: For outdoor use only.

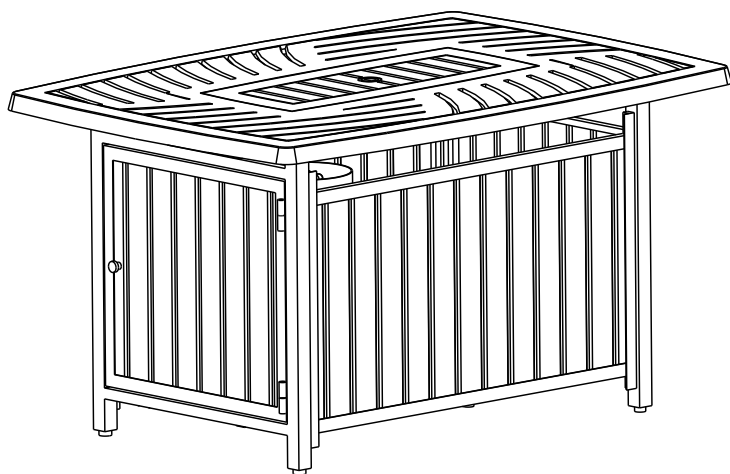

FOR YOUR SAFETY

If you smell gas:

1. Shut off gas to the appliance.
2. Extinguish any open flame.
3. If odour continues, immediately call gas supplier.

FOR YOUR SAFETY

Do not store or use gasoline or other flammable vapours or liquids in the vicinity of this or any other appliance.

For customer service, parts or warranty issues:
Call 1-800-561-5550
or e-mail customercare@jrhome.com



Conforms to ANSI STD Z21.97-2014, Certified to CSA STD
2.41-2014 Outdoor decorative gas appliances

Establishing a burner ignition for the FIRST time or after changing the cylinder tank may take up to 2-3 minutes in order for the gas to purge through the feeder lines.

FOR OUTDOOR USE ONLY
PLEASE READ INSTRUCTIONS CAREFULLY BEFORE ASSEMBLY
RETAIN THIS MANUAL FOR REFERENCE



Questions, problems, missing parts?

Before returning to your retailer, contact our exceptional customer service.

Contact us by email at customercare@jrhome.com or call us toll-free at
(800) 561-5550, 7:30 a.m. – 4:00 p.m., PST, Monday – Friday .

**** WARNING ****

Improper operation, installation, adjustment, alteration, servicing or maintenance cause severe property damage and /or serious damage and /or serious injury or death. Please read the installation, operating and maintenance instructions thoroughly before installing, operating or servicing this appliance.

PACKAGE CONTENTS	—————	Page 3
HARDWARE CONTENTS	—————	Page 4
ASSEMBLY INSTRUCTIONS	—————	Page 5-9
WARRANTY	—————	Page 10

**** For Your Safety ****

If you smell gas :

1. Shut off gas to appliance.
2. Extinguish any open flame.

**** For Your Safety ****

Do NOT store or use gasoline or other flammable vapors in the vicinity of this or any other appliance.



Establishing a burner ignition for the FIRST time or after changing the cylinder tank may take up to 2-3 minutes in order for the gas to purge through the feeder lines.

If stored indoors, detach and leave cylinder outdoors.

Keep this manual in your files for future reference.

NOTE : 20 lb., 5 Gallon LPG tank is not included.

***** IMPORTANT NOTICE*****

Do NOT return to place of purchase!!!
Please contact our Toll Free Hotline: 1-800-561-5550
for customer service and warranty issues
e-mail: customercare@jrhome.com
Hotline hours: Mon. to Fri. 7:30am - 4:00pm (P.S.T.)

Paramount

PACKAGE CONTENTS

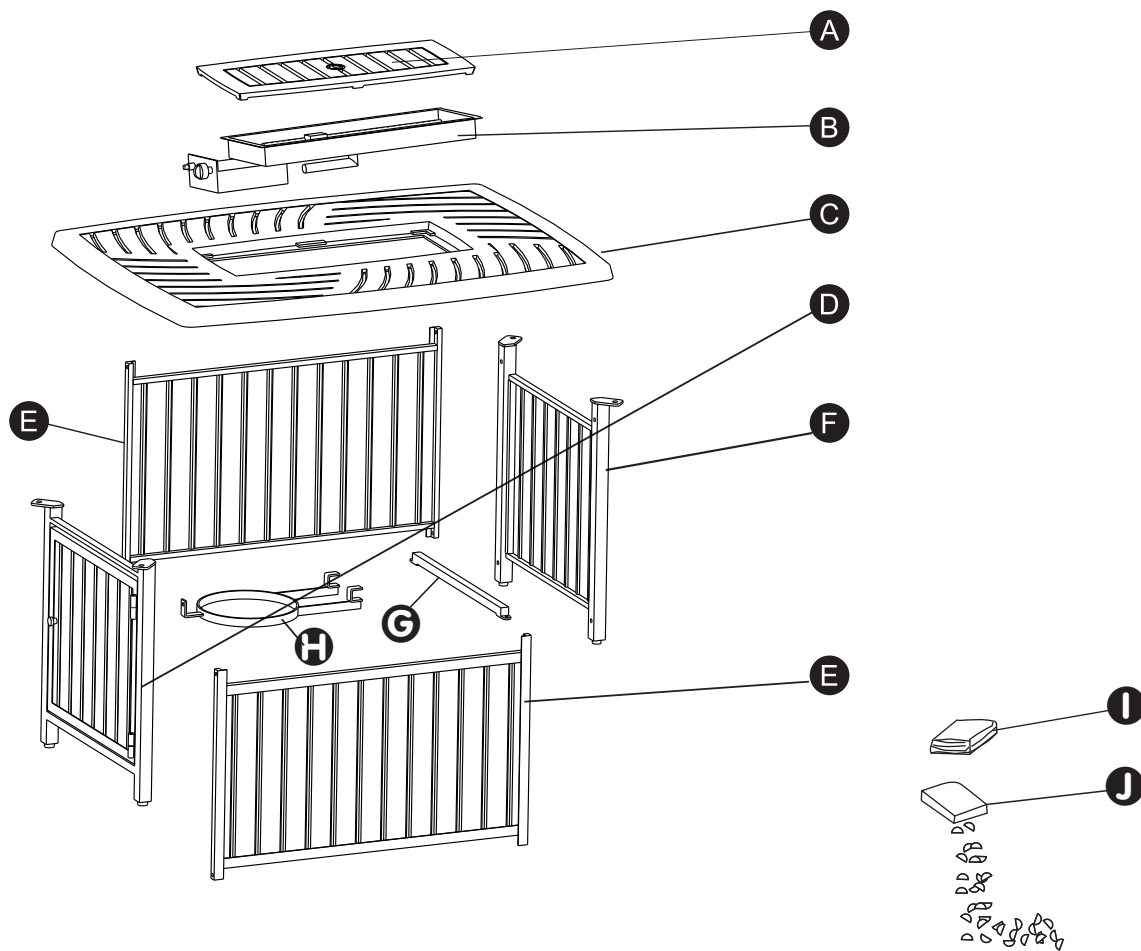

PART	DESCRIPTION	QUANTITY
A	Removable Burner Cover	1
B	Burner	1
C	Table Top	1
D	Door Panel	1
E	Side Panels	2
F	Back Panel	1
G	Tank Support Bar	1
H	Tank Support Ring	1
I	Protective Cover	1
J	Fire Glass	1



L

Bolt 8x30mm
Qty: 5

(4 for assembly +1 extra)

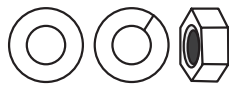

M

Washer/Spring Washer/Nut
(8mm)

Qty:5

(4 for assembly +1 extra)

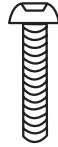

N

Bolt 6x25mm
Qty: 9

(8 for assembly +1 extra)



O

Bolt 6x18mm
Qty: 4

(3 for assembly +1 extra)



P

Washer 6mm
Qty: 12

(11 for assembly +1 extra)



U

Plastic Cap(M8)
Qty:4

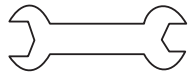

R

Wrench
Qty: 1



S

Hex Key/Wrench
Qty: 1

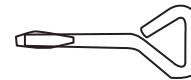

T

Screwdriver
Qty: 1



SAFETY INFORMATION

Please read and understand this entire manual before attempting to assemble, operate or install the product. Solid fuels shall not be burned in this appliance. If you have any questions regarding the product, please call customer service at 1-800-561-5550, 7am-4pm, PST, Monday - Friday. This appliance has been tested to and complies with the ANSI Z21.97-2010, Outdoor Decorative Gas Appliances CGA CR 97-003 Outdoor Gas Fireplaces. The installation must conform to local codes or in the absence of local codes to the National Fuel Gas Code, ANSI Z223.1. This manual contains important information about the assembly, operation and maintenance of this fire pit. General safety information is presented in these first few pages and is also located throughout the manual. Keep this manual for future reference and to educate new users of this product. This manual should be read in conjunction with the labeling on the product. Safety precautions are essential when any mechanical or propane fueled equipment is involved. These precautions are necessary when using, storing, and servicing. Using this equipment with the respect and caution demanded will reduce the possibilities of personal injury or property damage. The following symbols shown below are used extensively throughout this manual. Always heed these precautions, as they are essential when using any mechanical or fueled equipment.

⚠ DANGER

DANGER indicates an imminently hazardous situation which, if not avoided, will result in death or serious injury.

Solid fuels shall not be burned in this appliance.

PREPARATION



Before beginning assembly of product, make sure all parts are present. Compare parts with package contents list and hardware contents above. If any part is missing or damaged, do not attempt to assemble the product. Contact customer service for replacement parts.
Estimated Assembly Time : 60 minutes

Tools Required for Assembly (not included):

Phillips screwdriver w/ medium blade. Leak Detection Solution.

1. NOTE: It is best to assemble this gas fire pit using TWO PEOPLE. Locate all 4 Panels -D / E / F . Place a Spring Washer-P and Washer -P on each of 8 Bolts -N , then insert through holes on Side Panels -E into the holes on the Leg of Panels -D / F . Tighten all Bolts -N with Hex Key -S .
NOTE: the holes on Side Panels -E face down.

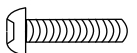

Hardware Used

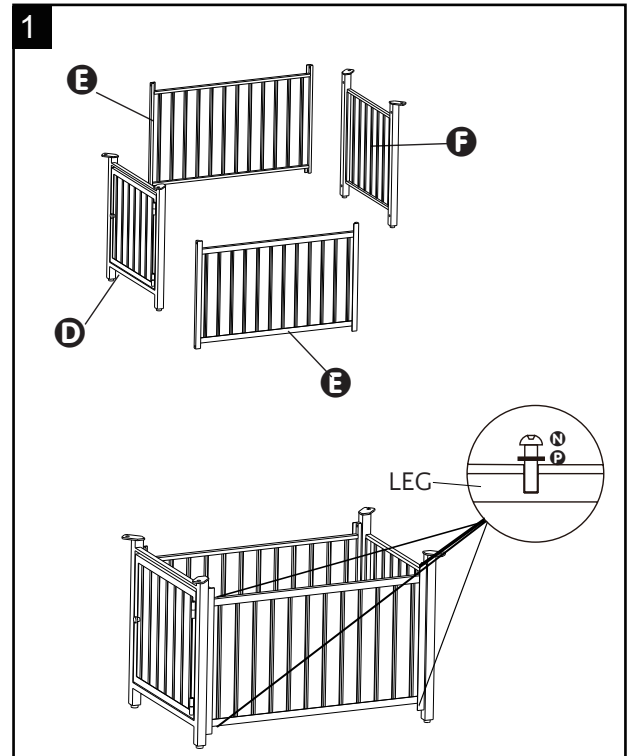
N Bolt (6*25mm)		X 8
P Washer(M6)		X 8
S Hex Key		X 1



2. Carefully turn the table base upside-down. Attach Gas Tank Support Bar -G to Side Panels -E by aligning holes in Gas Tank Support Bar with holes in the bottom of Side Panels. As shown in the figure above. Insert Bolt -O through Washer-P and then through hole. Tighten with Hex Key -S.

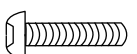

Hardware Used

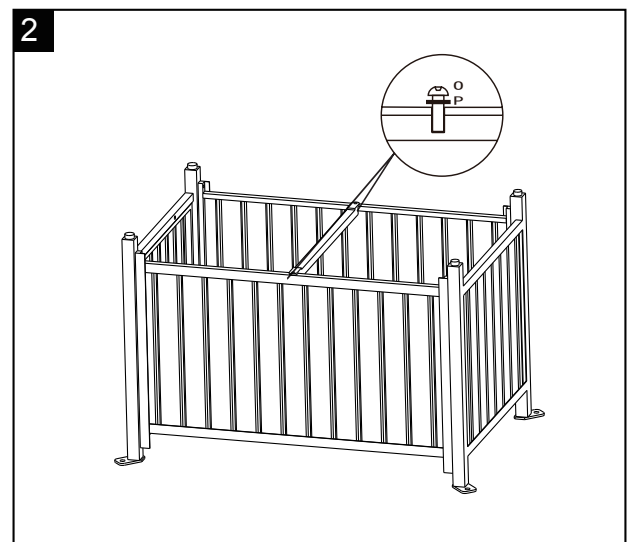
O Bolt (6*18mm)		X 2
P Washer(M6)		X 2
S Hex Key		X 1

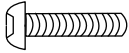

3. Fit bracket end of Gas Tank Support Ring-H over Gas Tank Support Bar-G and align hole on front of Gas Tank Support Ring with holes at the bottom of Front Door Panel-D. Insert Bolt-O through Washer P and then through hole. Tighten with Hex Key/Wrench-S.

Hardware Used





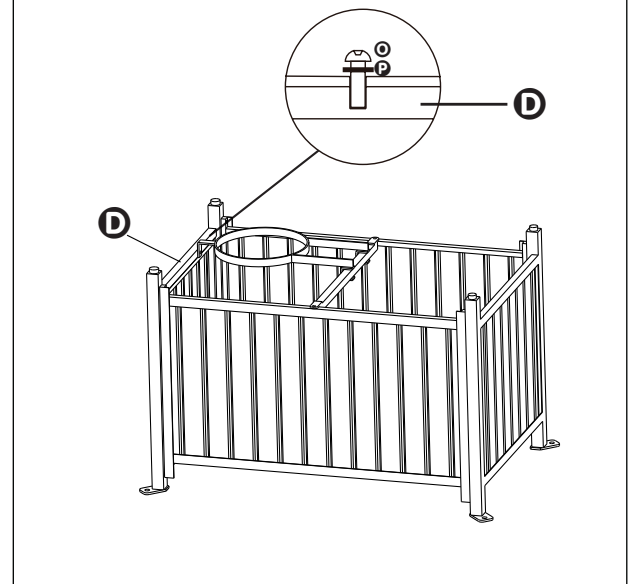

O Bolt (6*18mm)		X 1
P Washer(M6)		X 1
S Hex Key		X 1

3



4. Place Table Top-C so underside faces up. Screw 4 Studs-L into the holes on the Table Top with Screwdriver-T. Then carefully turn the assembled fire pit base upside-down and align the holes in the top of the Legs with the Studs in the Table Top. Place the holes over the Studs and secure each with Washer/ Spring Washer/Nut M as illustrated. Tighten with Wrench-R. Then place Plastic Caps-U over Nuts.

Hardware Used

L Stud (8*30mm)		X 4
M Washer(M8)		X 4
M Spring Washer(M8)		X 4
M Nut(M8)		X 4
U Plastic Cap (M8)		X 4
R Wrench		X 1
T Screwdriver		X 1

4

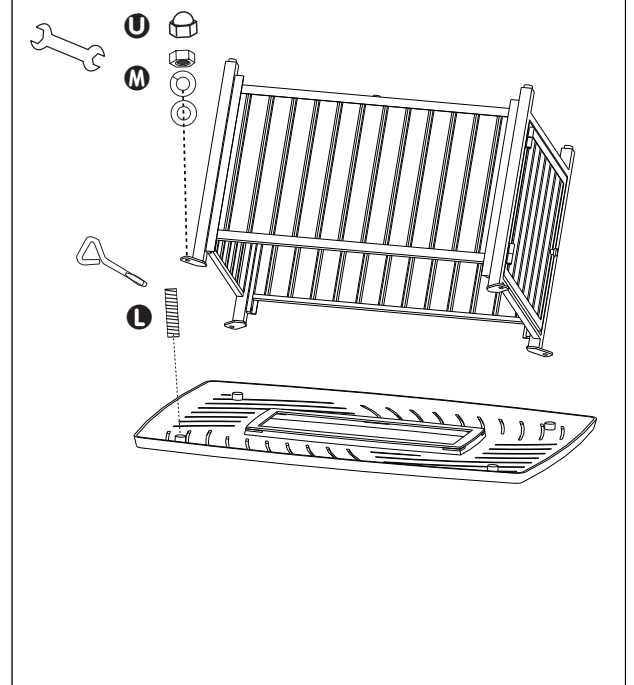

5. Gently place the Burner -B into the hole in the Table Top-C , allowing the hose and regulator to drop into the fire pit base. Make sure the Control Panel on the Burner faces the Front Door Panel -D

Unscrew the igniter button and insert a AAA Battery with positive end facing out. Screw the button back onto the control panel.

5

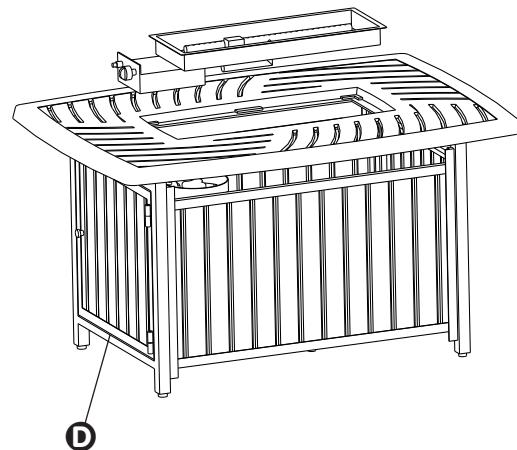

6. Pour the Fire Glass-K around the Burner. Be careful not to obstruct the pilot light housing. Put the Removable Burner Cover-A on the Burner when not in use. When the fire pit is not in use or after use, when the fire pit has cooled COMPLETELY, cover it with the Protective Cover-I. DO NOT PUT THE PROTECTIVE FIRE PIT COVER ON A HOT FIRE PIT.

6

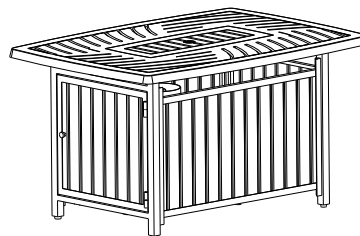
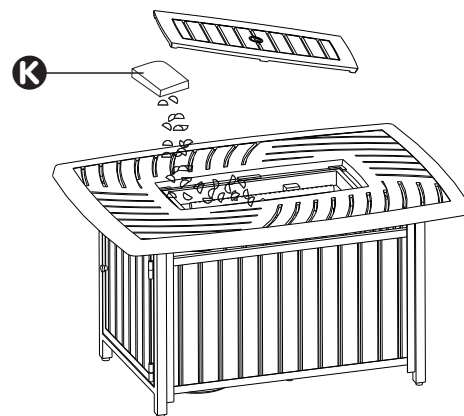

I

7. Connect hose and regulator to cylinder.
The propane gas and cylinder are sold separately.
Use a standard 20 lb. propane cylinder only.
Use this heater only with a propane vapor withdrawal supply system. See chapter 5 of the standard for storage and handling of liquefied petroleum gas, ANSI/NFPA58. Your local library or fire department should have this book.
Storage of an appliance indoors is permissible only if the cylinder is disconnected and removed from the appliance. A cylinder must be stored outdoors in a well-ventilated area out of the reach of children. A disconnected cylinder must have dust caps tightly installed and must not be stored in a building, garage or any other enclosed area.
The maximum inlet gas supply pressure: 250 psi. The minimum inlet gas supply pressure: 5 psi.
The minimum hourly of 10000 BTU is the required input rating for a heater for automatic operation at ratings less than full input rating.
The pressure regulator and hose assembly supplied with the appliance must be used ⑦.
The installation must conform with local codes, or in the absence of local codes, with national fuel gas code, ANSI Z223.1/NFPA45, natural gas and propane Installation Code, CSA B149.1, or propane storage and handling code, B149.2.

7

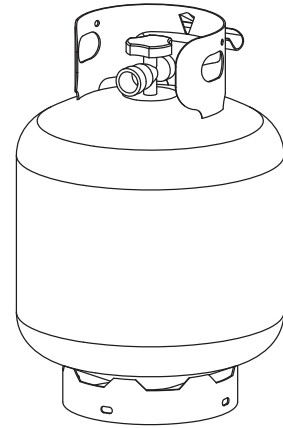

Standard 20 lb. tank

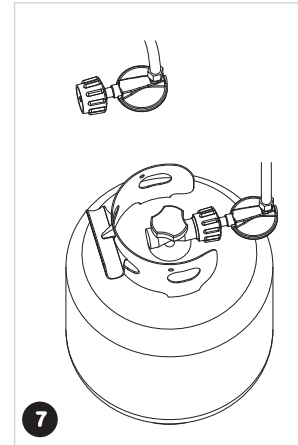

A dented, rusted or damaged propane cylinder may be hazardous and should be checked by your cylinder supplier. Never use a propane cylinder with a damaged valve connection.

The propane cylinder must be constructed and marked in accordance with the specifications for LP gas cylinders of the U.S. Department of Transportation (DOT) or the standard for cylinders, spheres and tubes for transportation of dangerous goods and commission, CAN/CSA-B339.

The cylinder must have a listed overfilling prevention device.

The cylinder must have a connection device compatible with the connection for the appliance.

The cylinder used must include a collar to protect the cylinder valve.

Never connect an unregulated propane cylinder to the heater.

Attach regulator to cylinder. Complete attachment. Install cylinder.

Secure the propane cylinder with the cylinder screw by tightening the screw until it comes in contact with the cylinder.

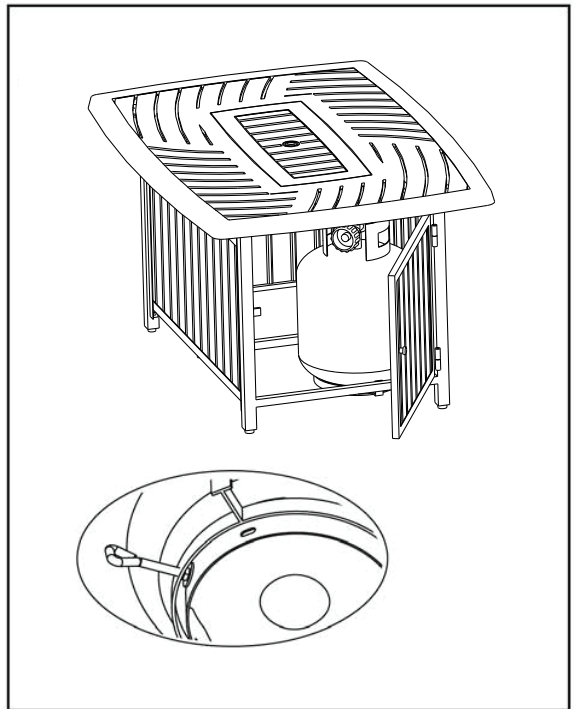
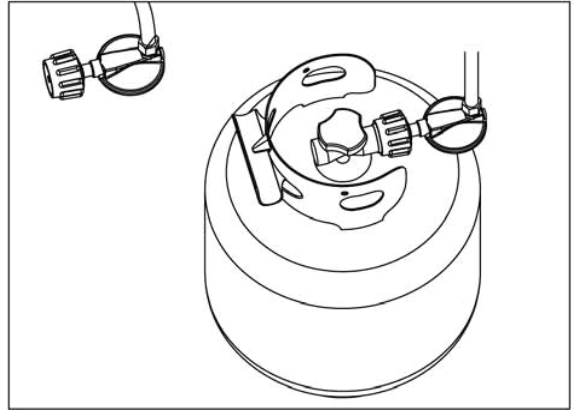

- Do not store a spare LP-gas cylinder under or near this appliance;
- Never fill the cylinder beyond 80 percent full;
- Place the dust cap on the cylinder valve outlet whenever the cylinder is not in use. Only install the type of dust cap on the cylinder valve that is provided with the cylinder valve. Other type of caps or plugs may result in leakage of propane.

ATTENTION: THIS PRODUCT IS NOT FOR COMMERCIAL USE. INTENDED FOR RESIDENTIAL USE ONLY.

Do not sit or stand on this fire pit table .

Keep children away during assembly, as this item contains small parts which can be swallowed by children.

Do not use indoors or inside any enclosure.

Retain the assembly instructions for future reference.

Installer – Please leave these instructions with the owner.

PROBLEM	POSSIBLE CAUSE	CORRECTIVE ACTION
Burner will not light	Propane cylinder is frosted over	Wait until the propane cylinder warms up and becomes unfrosted
	Blockage in orifice	Clear blockage
	Control knob is not in ON position	Turn control knob to ON
Burner flame is low	Gas pressure is low	Turn cylinder valve OFF and replace cylinder
	Outdoor temperature is less than 40°F and tank is less than 1/4 full	Use a full cylinder
	Control knob fully ON	Check burner and orifices for blockage
Carbon build-up Thick Black Smoke	Dirt or film on burner screen	Clean burner screen
	Blockage in burner	Remove blockage and clean burner screen inside and outside.

Warranty And Reviews



Extend Your Warranty By Leaving A Review

We want your opinion about your purchase...and we want you to tell everyone about it!

Just leave a review for the product on the retailers website where you made your purchase, or at www.jrhome.com, and fill in the online warranty at www.jrhome.com/warranty-registration within 30 days of purchase to receive a complimentary extra year of warranty protection.

Faites Part de Votre Évaluation et Prolongez Votre Garantie

Nous désirons connaître votre opinion sur nos produits ... et nous vous invitons à la partager!

Laissez simplement votre opinion concernant le produit sur le site internet du détaillant où vous avez fait votre achat ou au www.jrhome.com et remplissez la fiche de garantie en ligne au <https://www.jrhome.com/warranty-registration> afin de recevoir gratuitement une prolongation d'un an de la garantie de protection.

Follow us on/ Suivez-nous sur:



www.jrhome.com #jrhome #paramount

IMPORTANT

For questions, concerns or problems with our product please email our customer service department:

customercare@jrhome.com

DATED PROOF OF PURCHASE REQUIRED FOR WARRANTY SERVICE

Si vous éprouvez des difficultés ou si vous avez des questions ou des préoccupations, prière de faire parvenir un courriel à notre service à la clientèle

customercare@jrhome.com

UNE PREUVE D'ACHAT DATÉE EST REQUISE POUR SE PRÉVALOIR DE LA GARANTIE.

WARRANTY

This product is inspected, tested and carefully packaged to minimize the chance of damage during shipment. If a part (excluding light bulbs, glass and fuses*) within one year from the date of purchase proves to be defective in material or fabrication under normal use, the part will be repaired or replaced. The Company's obligation under the warranty is to replace or repair defective parts at our discretion. Any expenses or damage resulting from the installation, removal or transportation of the product will be the responsibility of the owner and are not covered by this warranty. The owner assumes all other risks arising from the use or misuse of the product. The warranty will be void if the product damage or failure is deemed by the Company to be caused by accident, alteration, misuse, abuse, incorrect installation or removal, or connection to an incorrect power source by the owner. The Company neither assumes, nor authorizes any person or entity to assume for it any obligation or liability associated with its products. Light bulbs and fuses are not covered under this warranty. If you have any questions regarding the warranty or service, please contact us at **customercare@jrhome.com**.

Customer Service :

JR Home Products

Unit 306 - 19100 Airport Way, Pitt Meadows, BC V3Y 0E2

Toll Free : 1-800-561-5550

E-mail : **customercare@jrhome.com**

AVERTISSEMENT

Ce produit a été soigneusement inspecté, testé et emballé afin de minimiser les risques de dommages durant le transport. Si l'une des pièces (à l'exception des verres, des ampoules électriques et des fusibles*) s'avère défectueuse au niveau de sa fabrication ou de ses matériaux dans l'année qui suit la date de l'achat suite à une utilisation normale, la pièce sera réparée ou remplacée. La compagnie est tenue de réparer ou remplacer les pièces défectueuses à sa discrétion, en vertu de la garantie. Tous frais ou dommage résultant de l'installation, du démantèlement ou du transport du produit demeurent la responsabilité du client et n'est pas couvert par cette garantie. Le client assume tout autre risque résultant de l'utilisation correcte ou fautive du produit. La garantie devient nulle si la compagnie détermine que le dommage ou le mauvais fonctionnement est causé par un accident, une modification, une mauvaise utilisation, un abus, une mauvaise installation ou un mauvais démantèlement ou un branchement à une source électrique inadéquate de la part du client. La compagnie n'est pas responsable et n'autorise quiconque, personne ou entité légale, à accepter de responsabilité ou obligation en son nom, en rapport avec ses produits. * Les ampoules électriques et les fusibles ne sont pas couverts par cette garantie. Pour toute question au sujet de la garantie ou du service, contacter le service à la clientèle à : **customercare@jrhome.com**.

Service à la clientèle:

JR Home Products

Unit 306 - 19100 Airport Way, Pitt Meadows BC V3Y 0E2 Numéro

sans frais: 1-800-561-5550

Courriel: **customercare@jrhome.com**

You MUST register your product within 30 days of purchase to receive warranty service.

Registration can be completed online at www.jrhome.com or by mailing this form.

Vous DEVEZ enregistrer votre produit dans les 30 jours suivant l'achat pour bénéficier du service de garantie.

L'enregistrement sera complet une fois que vous aurez posté ce formulaire ou que vous serez inscrit en ligne.

Warranty Registration Information Form / Formulaire d'enregistrement de la garantie

Name / Nom : _____

Street / Adresse : _____

City / Ville : _____

Province / Province : _____

Postal Code / Code postal : _____

Daytime Phone # / No téléphone jour : _____

Evening Phone # / No téléphone soir : _____

E-Mail Address / Courriel : _____

Product/Produit : _____

Place of Purchase / Lieu de l'achat : _____

Date of Purchase / Date de l'achat : _____

Model # / No de modèle : _____

Serial # / Numéro de série : _____

You MUST register your product to receive warranty service.

For warranty service, contact J&R Home Products at the address, phone numbers listed below within 30 days of purchase. Be sure to have your sales receipt and original date of purchase. All warranty service will be coordinated by J&R Home Products service center.

Vous DEVEZ enregistrer votre produit pour vous prévaloir de la garantie.

Afin de faire valoir la garantie, communiquez avec J&R Home Products à l'adresse et aux numéros indiqués ci-dessous dans les 30 jours suivant la date d'achat. Ayez en main votre reçu et la date d'achat. Toutes les demandes liées aux garanties seront traitées par le centre de service de J&R Home Products.